

FRONT VIEW

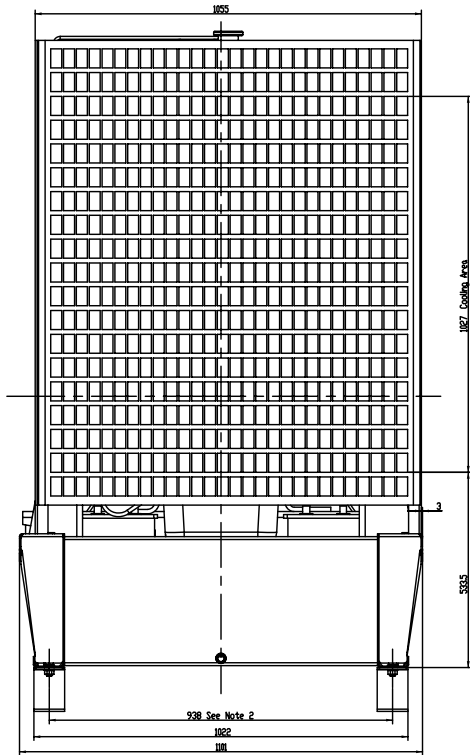

REAR VIEW

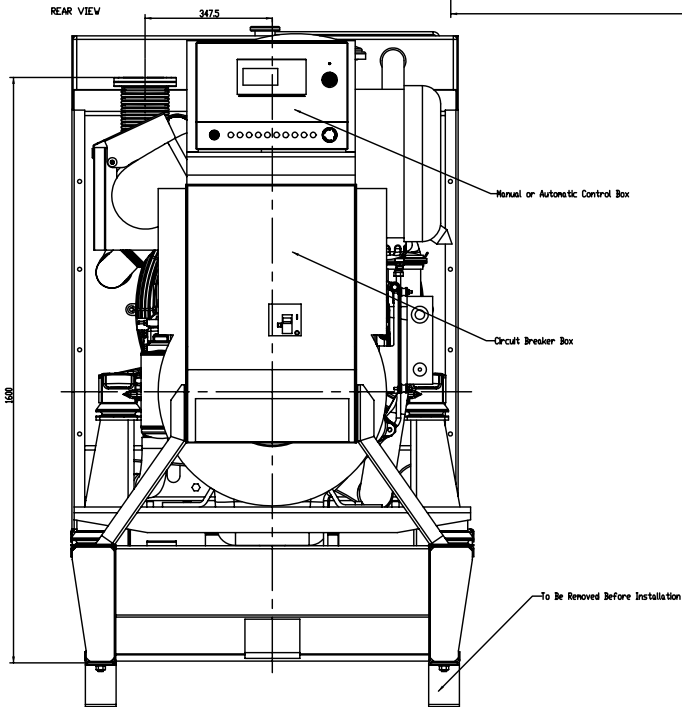

RIGHT SIDE VIEW

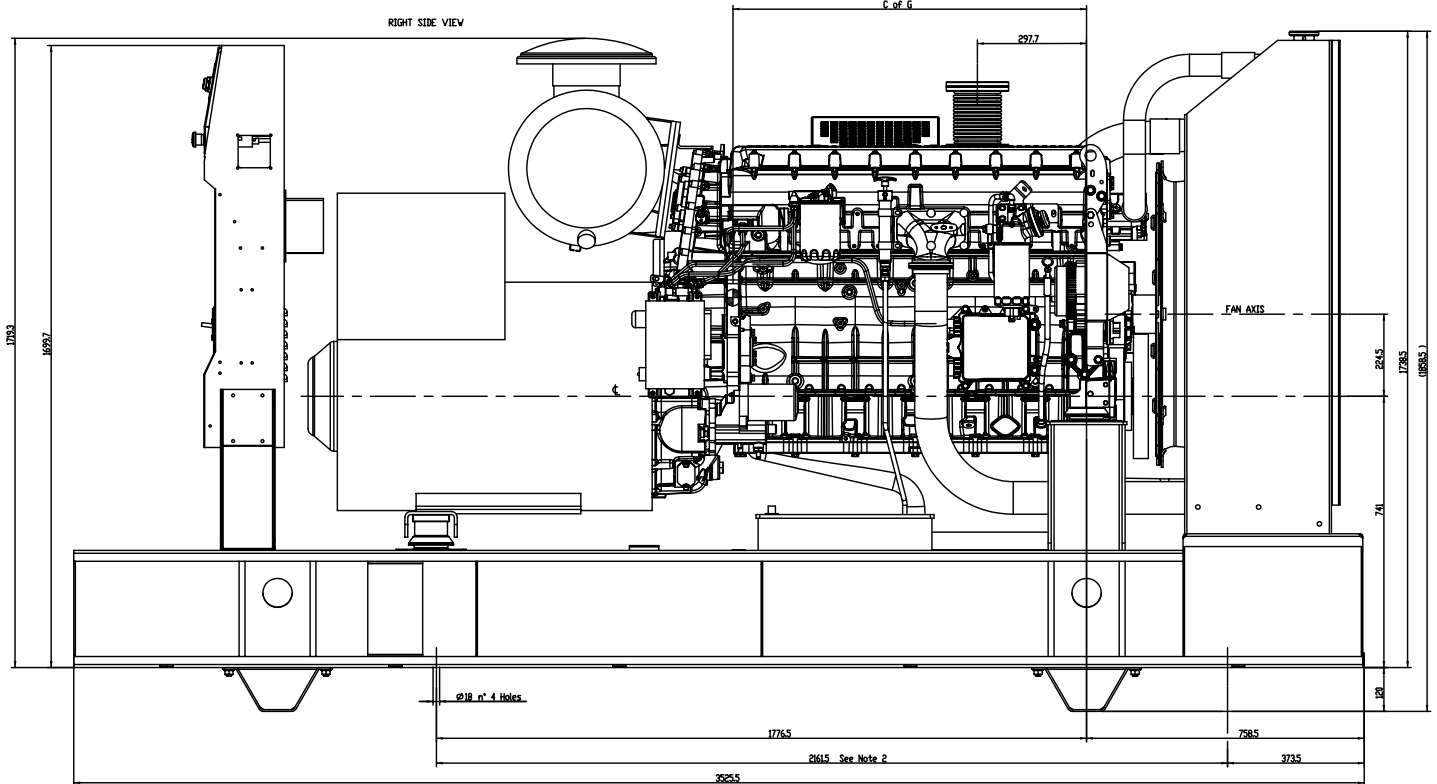

Exhaust Gas Counter-Flange
SCALE 1:2

SECTION C-C

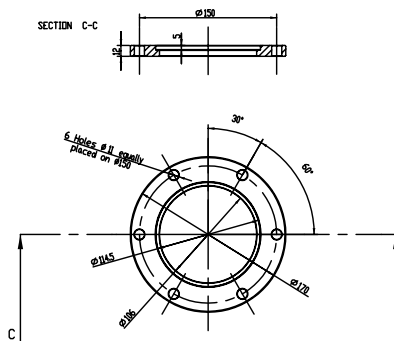

KVA	Generator Type	Dry Weight	C. of G
300	Marelli	2550 Kg	965
	Stanford	2668 Kg	974
	Mecc-Alte	2598 Kg	939
350	Marelli	2638 Kg	958
	Stanford	2753 Kg	1004
	Mecc-Alte	2648 Kg	994

NOTES:
1-Fuel Tank Capacity 500
1L
2-Installation Dimensions

CAD DRAWING
HANDLING ON CAD SYSTEM ONLY

Project Name: GE CURSOR 300E Drawing No: 503113438 D A 62-9710 Scale: 1:1 Date: 1994/01/11		Revision: 1 Date: 1994/01/11	
Author: [Name] Designer: [Name] Checker: [Name]		Project Manager: [Name] Location: [Name]	
Part Name: SCHEMA INGOMBRO Description: GENSET LAYOUT		Drawing Code: 194430	
Material: [Material] Quantity: [Quantity]		Weight: [Weight] Volume: [Volume]	

IVECO
 Iveco SpA
 GE CURSOR 300E